

FIRST ORIGINAL

(Forwarding Agents)

JAPAN FORWARDING AGENCY LTD.

S/O No.

YMO-075

B/L No.

NYKS181890560

Shipper

IBC JAPAN LTD  
64 MIYANOMAE-CHO NAKAJIMA  
FUSHIMI-KU KYOTO 612-8457 JAPAN  
TEL: 075-622-5090  
FAX: 075-622-5098

印紙税申告納  
付につき麹町  
税務署承認済



**NYK LINE**  
NIPPON YUSEN KAISHA

Consignee

KWIZERA MUGISHA MELVIN...  
1ST FLOOR MT OLIVE COUNTRY MALL  
169 NTINDA NAALYA ROAD  
KAMPALA  
UGANDA  
256777028540

**BILL OF LADING**

**(NON NEGOTIABLE UNLESS CONSIGNED TO ORDER)**

Shipped on board the Vessel, the Goods, or packages said to contain the cargo described below, in apparent good order and condition unless otherwise indicated herein, to be carried to the port of discharge or such port or place as selected by the Carrier under the terms and conditions of this Bill, with or without transshipment, as the Vessel and/or other connecting conveyances may safely get, and to be delivered there in like order and condition unto order or assigns, subject to the terms, conditions and exceptions on the face and back hereof.

This Bill (duly endorsed if it is negotiable) must be surrendered in exchange for the Goods or delivery order except where this Bill issued as a Sea Waybill. Where issued as a Sea Waybill, this Bill is not negotiable or a document of title and delivery shall be made to the named consignee on production of such reasonable proof of identity as may be required by the Carrier.

In accepting this Bill, the Merchant agrees to be bound by all the stipulations, exceptions, terms and conditions on the face and back hereof, whether written, typed, stamped or printed, as fully as if signed by the Merchant, any local custom or privilege to the contrary notwithstanding and agrees that all agreements or freight engagements for and in connection with the carriage of the Goods are superseded by this Bill.

In witness whereof, the undersigned, on behalf of Nippon Yusen Kaisha, the Master and the owner of the Vessel, has signed the number of Bill(s) stated below, all of this tenor and date, one of which being accomplished, the others to stand void.

Notify Party

KWIZERA MUGISHA MELVIN...  
1ST FLOOR MT OLIVE COUNTRY MALL  
169 NTINDA NAALYA ROAD  
KAMPALA  
UGANDA  
256777028540

(Local Vessel)

(From)

Ocean Vessel **036** Voy.No.

**GALAXY LEADER**

Port of Loading

**YOKOHAMA, JAPAN**

Port of Discharge

**MOMBASA, KENYA**

※ For Transshipment to (if on-carriage)

※ Final Destination (for the Merchant's reference only)

**UNI CFS**

Marks & Numbers	No. of P' kgs. or Units	Kind of packages or Units;	Description of Goods	Gross Weight (KGS)	Measurement (M3)
NO MARK	1	UNIT	USED MOTOR CARS 2007 TOYOTA RUMION ZRE152-1038699 2ZR A103649 HS CODE:8703.23 421X176X163  "FREIGHT PREPAID"	1,320	12.078

TOTAL NUMBER OF PACKAGES SAY: ONE (1) UNIT ONLY  
OR UNITS (IN WORDS)

Freight & Charges	Revenue Tons	Rate	Per	Prepaid	Collect
"FREIGHT PREPAID AS ARRANGED"					

ICS B/L	Ex. Rate	Prepaid at <b>KOBE, JAPAN</b>	Payable at	Place of B(s)/L Issue <b>KOBE, JAPAN</b>	Dated <b>19 MAR 2020</b>
		Total Prepaid in Local Currency	Number of Original B(s)/L <b>THREE (3)</b>	<b>NIPPON YUSEN KAISHA</b>	

(JSA STANDARD FORM B)

※See-Article 17

(TERMS OF BILL OF LADING CONTINUED ON BACK HEREOF)

**AS CARRIER  
YCS CO., LTD.  
AS AGENT FOR CARRIER**



Declared Value

If shipper enters a value, carrier's limitation of liability shall not apply and the usual maximum rate will be charged. (See Article 13 & 22)

THIRD ORIGINAL

JAPAN FORWARDING AGENCY LTD.

(Forwarding Agents)

S/O No.

YMO-075

B/L No.

NYKS181890560

Shipper  
IBC JAPAN LTD  
64 MIYANOMAE-CHO NAKAJIMA  
FUSHIMI-KU KYOTO 612-8457 JAPAN  
TEL: 075-622-5090  
FAX: 075-622-5098



**NYK LINE**  
NIPPON YUSEN KAISHA

Consignee  
KWIZERA MUGISHA MELVIN...  
1ST FLOOR MT OLIVE COUNTRY MALL  
169 NTINDA NAALYA ROAD  
KAMPALA  
UGANDA  
256777028540

**BILL OF LADING  
(NON NEGOTIABLE UNLESS CONSIGNED TO ORDER)**

Shipped on board the Vessel, the Goods, or packages said to contain the cargo described below, in apparent good order and condition unless otherwise indicated herein, to be carried to the port of discharge or such port or place as selected by the Carrier under the terms and conditions of this Bill, with or without transshipment, as the Vessel and/or other connecting conveyances may safely get, and to be delivered there in like order and condition unto order or assigns, subject to the terms, conditions and exceptions on the face and back hereof.

This Bill (duly endorsed if it is negotiable) must be surrendered in exchange for the Goods or delivery order except where this Bill issued as a Sea Waybill. Where issued as a Sea Waybill, this Bill is not negotiable or a document of title and delivery shall be made to the named consignee on production of such reasonable proof of identity as may be required by the Carrier.

In accepting this Bill, the Merchant agrees to be bound by all the stipulations, exceptions, terms and conditions on the face and back hereof, whether written, typed, stamped or printed, as fully as if signed by the Merchant, any local custom or privilege to the contrary notwithstanding and agrees that all agreements or freight engagements for and in connection with the carriage of the Goods are superseded by this Bill.

In witness whereof, the undersigned, on behalf of Nippon Yusen Kaisha, the Master and the owner of the Vessel, has signed the number of Bill(s) stated below, all of this tenor and date, one of which being accomplished, the others to stand void.

Notify Party  
KWIZERA MUGISHA MELVIN...  
1ST FLOOR MT OLIVE COUNTRY MALL  
169 NTINDA NAALYA ROAD  
KAMPALA  
UGANDA  
256777028540

(Local Vessel) (From)  
Ocean Vessel **036** Voy.No. Port of Loading  
**GALAXY LEADER** **YOKOHAMA, JAPAN**

Port of Discharge **MOMBASA, KENYA** \*For Transshipment to (if on-carriage) \*Final Destination (for the Merchant's reference only)  
**UNI CFS**

Marks & Numbers	No. of P' kgs. or Units	Kind of packages or Units	Description of Goods	Gross Weight (KGS)	Measurement (M3)
NO MARK	1	UNIT	USED MOTOR CARS 2007 TOYOTA RUMION ZRE152-1038699 2ZR A103649 HS CODE:8703.23 421X176X163 "FREIGHT PREPAID"	1,320	12.078

TOTAL NUMBER OF PACKAGES SAY: ONE (1) UNIT ONLY  
OR UNITS (IN WORDS)

Freight & Charges	Revenue Tons	Rate	Per	Prepaid	Collect
"FREIGHT PREPAID AS ARRANGED"					

ICS B/L	Ex. Rate	Prepaid at <b>KOBE, JAPAN</b>	Payable at	Place of B(s)/L Issue <b>KOBE, JAPAN</b>	Dated <b>19 MAR 2020</b>
		Total Prepaid in Local Currency	Number of Original B(s)/L <b>THREE (3)</b>	<b>NIPPON YUSEN KAISHA</b>	

(JSA STANDARD FORM B) \*See-Article 17 (TERMS OF BILL OF LADING CONTINUED ON BACK HEREOF)

AS CARRIER  
YCS CO., LTD.  
AS AGENT FOR CARRIER



Declared Value

If shipper enters a value, carrier's limitation of liability shall not apply and the ad valorem rate will be charged. (See Article 13 & 22)

# IBC JAPAN LTD.

64 Miyanomae-cho, Nakajima,  
Fushimi-ku, Kyoto Japan



The Global Source  
of Pre-Owned Vehicles

Phone: +81 75 422 5090

Fax: +81 75 422 2400

24/7 Hotline: +81 3-4335 9355

Email: accounts@ibc-auto.com

Website: ibc-japan.com

## INVOICE

MESSRS KWIZERA MUGISHA MELVIN...  
1ST FLOOR MT OLIVE COUNTRY MALL  
169 NTINDA NAALYA ROAD  
KAMPALA  
COUNTRY UGANDA

DATE 3/19/2020  
INVOICE NO. 85330245230

SHIPPED PER: Galaxy Leader-YK  
FROM: Yokohama

TO: Mombasa, Kenya

SAILING ON/OR ABOUT: 3/19/2020

TERMS: T/T

DESCRIPTION & QUANTITY  
USED MOTOR CARS

AMOUNT

CIF Mombasa in USD

1	TOYOTA RUMION	2007 ZRE152-1038699	2ZR A103649	SILVER	USD	2,055
---	---------------	---------------------	-------------	--------	-----	-------

ONE UNIT(S) TOTAL

TOTAL:

2,055

MARK & NO.

NO MARK

IBC Japan Ltd.

# EAA

## Certificate of export inspection

### EAA Company Limited



No: UH-2003-016-001  
Date of Issue: 2020/03/09  
Date of Appraisal: 2020/03/05

We hereby certify that the undermentioned motor vehicle was inspected by the EAA Company Limited and found to conform to the requirements of

### UGANDA STANDARDS US 845:2017

Make	<u>TOYOTA</u>	Model	<u>DBA-ZRE152N</u>
Type of Vehicle			<u>Sedan</u>
Engine Capacity(c.c.rating)			<u>1,790 CC</u>
Year of First Registration			<u>2007/12</u>
Chassis Number			<u>ZRE152-1038699</u>
Engine Number or Model			<u>2ZR A103649</u>
Inspected Mileage(Odometer Reading)			<u>106,229 km</u>
Inspected Date			<u>2020/03/05</u>

Remarks: We hereby certify that this motor vehicle does not exceed the radiation threshold level.

Note 1: No responsibility can be taken for alteration made to vehicle after this inspection.

Note 2: No responsibility can be assumed by this institute for any disputes, reparations, etc. caused by transaction involving the certified used motor vehicle as abovementioned.

EAA Company Limited



Director of  
Inspection Dept

EAA Head Office



*[Signature]*



Inspection fee US\$140,00

NO UH-2003-016-001

This certificate is issued on the understanding that it does not relieve the seller from this contractual obligation.

**THIS CERTIFICATE IS VALID FOR A PERIOD OF THREE(3) MONTHS FROM THE DATE OF ISSUE**



S/No. UH-2003-016-001

[Vehicle Details]

Chassis No: ZRE152-1038699 Model: DBA-ZRE152N Engine Model: 2ZR
Maker: TOYOTA 1st Registration Year: 2007/12 Engine No: A103649
Model Name: TOYOTA Manufacturing Year: 2007 Weight: 1320 Kg
Engine Capacity: 1790 cc Type of Vehicle: Sedan FF Axis Weight: 820 Kg
Body Color: Silver Mileage(Paper): 69,800 Km FR Axis Weight: Kg
Fuel Type: GASOLINE Odometer: 106,229 km RF Axis Weight: Kg
RR Axis Weight: 500 Kg

[Inspection Details]

Location: Kisarazu Inspector: Shinji Misawa

[Test Drive]

Table with 4 columns: Test Item, Pass/Fail, [Exhaust], Pass/Fail, [Headlights], Pass/Fail. Rows include Abnormal at Acceleration, Abnormal at Brake Test, CO, HC, DS, Luminance R, Luminance L, Attachment R, (Height) L.

[Side Slip]

Table with 2 columns: Test Item, Pass/Fail. Row: IN / OUT 1.0 mm.

[Speedometer]

Table with 2 columns: Test Item, Pass/Fail. Rows: Difference 1.1 km/h, Run-out 0 km/h.

[Brake System]

Table with 4 columns: Item, Weight, Calculation, Result, Item, Weight, Calculation, Result. Rows include Sum main brake, Sum parking brake, Sum R wheel brake, Pull:Front, Pull:Rear.

[Engine]

Table with 2 columns: Item, Result. Rows include Engine, Fan belt, Battery, Master Cylinder, Caburetor, Fuel Pipes, Injection Pump, Wiring Haeness, Generator, Cooling Syatem, Manifolds, Lubrication System, CFC.

[Equipment]

Table with 2 columns: Item, Result. Rows include Tool, Jack.

[Accessory]

Table with 2 columns: Item, Result. Rows include A/C, Audio, Navigation, Alloy Wheel. AT/MT: AT

[Underbody]

Table with 2 columns: Item, Result. Rows include Wheel Bearing, Springs, Shock Absorbers, Suspension Fixing, Torque Rod, Gear Box, Steering Rod/Arm, Wheel Cylinder, Brake Rod/Cable, Breake Hose/Pipe, Front axle, Drive Shaft, Propeller Shaft, Axle Housing, Differential, Tyre Size, Tyre Condition, Tyre ETC.

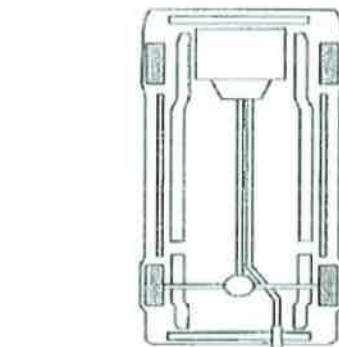
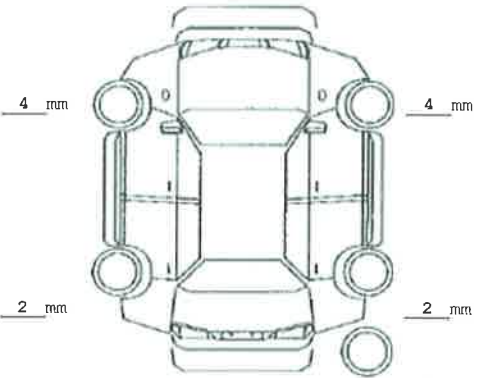

[Interior]

Table with 2 columns: Item, Result. Rows include Steering Wheel, Power Steering, Horn, Gauges, Climate Control, Door, Windows, Wipers, Mirrors(Back & Sides), Shift Lever, Safety Belts, Brake Pedal, Brake Booster, Clutch Pedal, Clutch Function.

[Lights]

Table with 2 columns: Item, Result. Rows include Head lamp, Indicator, Rear, Brake, ETC.

[ETC]

Table with 2 columns: Item, Result. Rows include Exhaust System, Air Suspension, Air Brake, Fuel Tank.

[Damage]

Table with 2 columns: Item, Result. Rows include Exterior, Interior, Underbody.

F=Repair A=Scratch U=Dent R=Rust CR=Crack D=Damage

[Result]

Pass [checked] Fail

Inspector Signature Shinji Misawa
Inspection Date 2020-03-05

[Reinspection]

Pass Fail

Inspector Signature
Inspection Date2

[Fail Parts]

Empty box for fail parts

番号 01053  
整理番号 3621023993227874

# 輸出予定届出証明書 / Export Certificate

自動車登録番号 / Registration No. 京都 399 め 2787 車名 / Trademark of the maker of the vehicle 令和 1 年 10 月 17 日 平成 19 年 12 月 2007 型式 / Model ZRE152-1038699 原動機の型式 / Engine Model 2ZR

登録年月日 / Registration Date 初年度登録年月 / First Reg. Date 車台番号 / Maker's serial number [194] DBA-ZRE152N [26009 4798]

所有者の氏名又は名称 Name of Owner トヨタ IBC Japan 株式会社

所有者の住所 Address of Owner 京都府京都市伏見区中島宮ノ前町64

使用者の氏名又は名称 Name of User 使用の本拠の位置 Locality of principal about of use 使用の本拠の住所 Address of User

自動車の種別 Classification of Vehicle 用途 Purpose 乗車定員 Fixed Number 最大積載量 Max. Carry 車両重量 Weight

普通 乗用 家用 箱型 [001] 長さ 5人 幅 高さ 前前軸重 前後軸重 前後軸重 前後軸重 後後軸重  
Line Capacity 1.79 ガソリン 燃料の種別 Classification of fuel 型式指定番号 Specification No. 15963 類別区分番号 Classification No. 0002 長さ Length 421cm 幅 Width 176cm 高さ Height 163cm 前前軸重 FF Weight 820kg 前後軸重 FR Weight 1320kg 前後軸重 RF Weight 1595kg 後後軸重 RR Weight 500kg

輸出予定日 (証明書の有効期間満了日) 令和 2 年 4 月 16 日 輸出予定届出日 (証明書の有効期間満了日) 令和 2 年 4 月 16 日

備考  
【京都】、輸出予定届出に係る自動車は、輸出予定届出証明書の有効期間が満了した輸  
輸出されること、届出をなく、当該輸出が満了した日から15日以内に、最寄りの運輸  
支局等に当該輸出予定届出証明書を返納しなければなりません。  
【走行距離計表示値 / Mileage】 (平成29 (2017) 年4月7日)  
69,800 km (平成27 (2015) 年3月13日)  
【旧走行距離計表示値 (平成27 (2015) 年3月13日)】  
42,500 km  
以下余白

令和 1 年 10 月 17 日  
Director-General of the District Transport Bureau of  
Ministry of Land, Infrastructure, Transport and Tourism, Japan  
京都運輸支局長

裏面もご覧下さい。

No. 01053

## EXPORT CERTIFICATE

	License number	Last reg. Date	First reg. Month	Frame number						
KYOTO	399 ME 2787	October, 17, 2019	December, 2007	ZRE152-1038699						
	Name		Model	Engine model						
TOYOTA		[ 194 ]	DBA-ZRE152N	2ZR						
Last owner's name	IBC JAPAN KABUSHIKIGAISHA									
Above address	KYOTO-FU KYOTO-SHI FUSHIMI-KU NAKAJIMA MIYANOMAE-CHO 64									
Last user's name	*****									
Above address	*****									
Above location	*****									
Category	Purpose of use	Private or commercial	Style of Vehicle	Personal capacity	Cargo capacity	Net weight	Gross weight			
MEDIUM	Passenger	PRIVATE	SEDAN	5 <small>people</small>	- kg	1320 kg	1595 kg			
Displacement or outputpower kw	Fuel	Type No.	Code no.	Length	Width	Height	F.F weight	F.R.	R.F.	R.R. weight
1.79 L	PETROL	15963	0002	421 cm	176 cm	163 cm	820 kg	- kg	- kg	500 kg
EXPIRY DATE	April, 16, 2020									
REMARK:	[ KYOTO ]									

October, 17, 2019

KYOTO UNYU SHIKYOKU-CHO

We IBC JAPAN LTD. verify that this English translation of

Certificate Registration is exactly the same with the original Japanese edition