

Shipper  
 IBC JAPAN LTD  
 64 MIYANOMAE-CHO NAKAJIMA  
 FUSHIMI-KU KYOTO 612-8457 JAPAN  
 TEL: 075-622-5090 FAX: 075-622-5098

Booking No. **18001363731** B/L No. **MOLU18001311018**

**BILL OF LADING**

SHIPPED on board the Goods, or the total number of Containers or other packages or units enumerated below (\*) in apparent external good order and condition except as otherwise noted for transportation from the Port of Loading to the Port of Discharge subject to the terms hereof. One of the original Bills of Lading must be surrendered duly endorsed in exchange for the Goods or Delivery Order unless otherwise provided herein. In accepting this Bill of Lading the Merchant expressly accepts and agrees to all its terms whether printed, stamped or written, or otherwise incorporated, notwithstanding the non-signing of this Bill of Lading by the Merchant. IN WITNESS whereof the number of original Bills of Lading stated below have been signed, one of which being accomplished, the other(s) to be void. (Terms of Bill of Lading continued on the back hereof)  
 Declared value USD \_\_\_\_\_ subject to clause 5 (5) overleaf. If no value declared, liability limit applies as per clause 5 (4) or 32 as applicable.

Consignee (not negotiable unless consigned 'to order')  
 SHERITA BUSINGYE  
 P.O BOX 36735  
 KAMPALA UGANDA  
 256 782 622229

Also Notify (For the Merchant's reference only)

THE SHIPMENT ARE USED CAR(S) (SECOND-HAND CAR(S)) , NOT NEW CAR(S). THE CARRIER IS NOT RESPONSIBLE FOR ANY DENT, INDENTATION, SCRATCH, BREAKAGE, AND /OR DISCOLORATION WHICH ARE COMMON TO USED CARS, UNLESS IT IS PROVED THAT THEY WERE CAUSED BY THE CARRIER'S NEGLIGENCE. THE CARRIER IS NOT RESPONSIBLE FOR ANY CONTENTS, EQUIPMENTS, ACCESSORIES, AND D/OR SPARE PARTS OF USED CARS.

Notify Party  
 PAUL KAIGGWA  
 PLOT6 COLVILLE STREET,  
 AIRWAYS HOUSE GROUND FLOOR,  
 OPPOSITE EMIRATES AIRWAYS,  
 KAMPALA, UGANDA, \*\*\*

\*\*\* Local vessel From

Ocean vessel/Voy. No. 0063A Port of loading  
 GRACIOUS ACE KOBE, JAPAN

Port of discharge MOMBASA For transhipment to Final destination (for the Merchant's reference only)  
 UGANDA, MOMBASA CFS; BFT CFS

Marks & Numbers	No. of pkgs. or Units / Kind of packages; description of goods	Gross Weight	Measurement
		(KGS)	(M3)
NO MARK	FREIGHT PREPAID 1 UNIT(S) USED MOTOR CARS  MITSUBISHI OUTLANDER 2009 CW5W-5303187 4B12 NA 464X180X168 HS CODE: 8703.23  FREIGHT PREPAID AS ARRANGED *** TEL +256-782753967	1,530.000	14.031



\* Total number of packages or units. ONE UNIT

Code	Tariff Item	Basis	Freighted as	Curr.	Rate	Per	Prepaid	Collect
------	-------------	-------	--------------	-------	------	-----	---------	---------

**A S A R R A N G E D**

No. of Originals THREE	Place and date of B/L issue: KOBE MAR. 27. 2020	Totals & Pay at:
---------------------------	---	------------------

Date **MAR. 27. 2020** Signature NORDIC AGENCIES Mitsui O.S.K. Lines, Ltd. as Carrier  
 As Agents By *Daiya Jono* NORDIC AGENCIES As Agents

**FIRST ORIGINAL**

\* OA 838 Applicable if carriage by local vessel to Port of Loading or Ocean vessel arranged by carrier as agent for the Merchant in accordance with clause 7.  
 For the Carrier

Particulars furnished by shipper

**Shipper**  
 IBC JAPAN LTD  
 64 MIYANOMAE-CHO NAKAJIMA  
 FUSHIMI-KU KYOTO 612-8457 JAPAN  
 TEL: 075-622-5090 FAX: 075-622-5098

**Booking No.** 18001363731 **B/L No.** MOLU18001311018

**BILL OF LADING**

SHIPPED on board the Goods, or the total number of Containers or other packages or units enumerated below (\*) in apparent external good order and condition except as otherwise noted for transportation from the Port of Loading to the Port of Discharge subject to the terms hereof. One of the original Bills of Lading must be surrendered duly endorsed in exchange for the Goods or Delivery Order unless otherwise provided herein. In accepting this Bill of Lading the Merchant expressly accepts and agrees to all its terms whether printed, stamped or written, or otherwise incorporated, notwithstanding the non-signing of this Bill of Lading by the Merchant. IN WITNESS whereof the number of original Bills of Lading stated below have been signed, one of which being accomplished, the other(s) to be void. (Terms of Bill of Lading continued on the back hereof)  
 Declared value USD \_\_\_\_\_ subject to clause 5 (5) overleaf. If no value declared, liability limit applies as per clause 5 (4) or 32 as applicable.

**Consignee (not negotiable unless consigned 'to order')**  
 SHERITA BUSINGYE  
 P.O BOX 36735  
 KAMPALA UGANDA  
 256 782 622229

**Also Notify** (For the Merchant's reference only)

THE SHIPMENT ARE USED CAR(S) (SECOND-HAND CAR(S)) , NOT NEW CAR(S). THE CARRIER IS NOT RESPONSIBLE FOR ANY DENT, INDENTATION, SCRATCH, BREAKAGE, AND /OR DISCOLORATION WHICH ARE COMMON TO USED CARS, UNLESS IT IS PROVED THAT THEY WERE CAUSED BY THE CARRIER'S NEGLIGENCE. THE CARRIER IS NOT RESPONSIBLE FOR ANY CONTENTS, EQUIPMENTS, ACCESSORIES, AND D/OR SPARE PARTS OF USED CARS.

**Notify Party**  
 PAUL KAIGGWA  
 PLOT6 COLVILLE STREET,  
 AIRWAYS HOUSE GROUND FLOOR,  
 OPPOSITE EMIRATES AIRWAYS,  
 KAMPALA, UGANDA, \*\*\*

\*\*\* Local vessel From

Ocean vessel/Voy. No. 0063A Port of loading  
 GRACIOUS ACE KOBE, JAPAN

Port of discharge MOMBASA For transhipment to Final destination (for the Merchant's reference only)  
 UGANDA, MOMBASA CFS; BFT CFS

Marks & Numbers	No. of pkgs. or Units / Kind of packages; description of goods	Gross Weight (KGS)	Measurement (M3)
NO MARK	FREIGHT PREPAID 1 UNIT(S) USED MOTOR CARS  MITSUBISHI OUTLANDER 2009 CW5W-5303187 4B12 NA 464X180X168 HS CODE: 8703.23  FREIGHT PREPAID AS ARRANGED *** TEL +256-782753967	1,530.000	14.031

\* Total number of packages or units. ONE UNIT

Code	Tariff Item	Basis	Freighted as	Curr.	Rate	Per	Prepaid	Collect
------	-------------	-------	--------------	-------	------	-----	---------	---------

**A S A R R A N G E D**

No. of Originals THREE Place and date of B/L issue: MAR. 27, 2020 Totals & Pay at:

ON BOARD Date MAR. 27, 2020 Signature NORDIC AGENCIES

**THIRD ORIGINAL**

Mitsui O.S.K. Lines, Ltd. as Carrier

By *Daiya Yano* As Agents

As Agents

\* OA 838  
 \*\* Applicable if carriage by local vessel to port of loading or ocean vessel arranged by carrier as agent for the Merchant in accordance with clause 7.

Particulars furnished by shipper

# IBC JAPAN LTD.

64 Miyanomae-cho, Nakajima,  
Fushimi-ku, Kyoto Japan



The Global Source  
of Pre-Owned Vehicles

Phone: +81 75 622 5000 Fax: +81 75 622 2400 24/7 Hotline: +81 3 6438 0358 Email: accounts@ibc.co.jp Website: ibc.co.jp

## INVOICE

MESSRS SHERITA BUSINGYE  
P.O BOX 36735  
KAMPALA  
COUNTRY UGANDA

DATE 3/27/2020  
INVOICE NO. 87075745280

SHIPPED PER: Gracious Ace-KB SAILING ON OR ABOUT: 3/27/2020  
FROM: Kobe TO: Mombasa, Kenya TERMS: T/T

<u>DESCRIPTION &amp; QUANTITY</u>					<u>AMOUNT</u>
USED MOTOR CAR(S)					CIF Mombasa in USD
1	MITSUBISHI OUTLANDER	2009 CW5W-5303187	4B12 NA	BLACK	USD 7,724
ONE UNIT(S) TOTAL				TOTAL:	7,724

MARK & NO.

NO MARK

IBC Japan Ltd.

# EAA

## Certificate of export inspection

### EAA Company Limited



No.: UH-2003-069-001  
Date of Issue: 2020/03/16  
Date of Appraisal: 2020/03/13

We hereby certify that the undermentioned motor vehicle was inspected by the EAA Company Limited and found to conform to the requirements of  
**UGANDA STANDARDS US 845:2017**

Make	<u>  MITSUBISHI  </u>	Model	<u>  DBA-CW5W  </u>
Type of Vehicle			<u>  Station Wagon  </u>
Engine Capacity(c.c.rating)			<u>  2,350  </u> CC
Year of First Registration			<u>  2009/03  </u>
Chassis Number			<u>  CW5W-5303187  </u>
Engine Number or Model			<u>  4B12  </u> NA
Inspected Mileage(Odometer Reading)			<u>  50,191  </u> km
Inspected Date			<u>  2020/03/13  </u>

Remarks: We hereby certify that this motor vehicle does not exceed the radiation threshold level.

Note 1: No responsibility can be taken for alteration made to vehicle after this inspection.

Note 2: No responsibility can be assumed by this institute for any disputes, reparations, etc. caused by transaction involving the certified used motor vehicle as abovementioned.

EAA Company Limited

EAA West



Director of  
Inspection Dept

Inspection fee US\$140,00



NO UH-2003-069-001

This certificate is issued on the understanding that it does not relieve the seller from this contractual obligation.

**THIS CERTIFICATE IS VALID FOR A PERIOD OF THREE(3) MONTHS FROM THE DATE OF ISSUE**



S/No. UH-2003-069-001

[Vehicle Details]

Chassis No: CW5W-5303187 Model: DBA-CW5W Engine Model: 4B12
Maker: MITSUBISHI 1st Registration Year: 2009/03 Engine No: NA
Model Name: Manufacture Year: 2009 Weight: 1530 Kg
Engine Capacity: 2350 cc Type of Vehicle: Station Wagon FF Axis Weight: 860 Kg
Body Color: Black Mileage(Paper): 44,700 Km FR Axis Weight: Kg
Fuel Type: GASOLINE Odometer: 50,191 km RF Axis Weight: Kg
RR Axis Weight: 670 Kg

[Inspection Details]

Location: Kobe Inspector: Kazuya Kawashima

[Test Drive]

Abnormal at Acceleration Pass/Fail [check]
Abnormal at Brake Test Pass/Fail [check]

[Exhaust]

CO 0.00 % Pass/Fail [check]
HC 0 ppm Pass/Fail [check]
DS %/m-1 Pass/Fail [check]

[Headlights]

Luminance R 320 x100cd Pass/Fail [check]
L 380 x100cd Pass/Fail [check]
Attachment R cm Pass/Fail [check]
(Height) L cm Pass/Fail [check]
Optical Axis R cm Pass/Fail [check]
(Under) L cm Pass/Fail [check]
Optical Axis R cm Pass/Fail [check]
(RL) L cm Pass/Fail [check]

[Side Slip]

IN / OUT 1.3 mm Pass/Fail [check]

[Exhaust proximity noise] Pass/Fail [check]
Average dB(A) Pass/Fail [check]

[Speedometer]

Difference 0.2 km/h Pass/Fail [check]
Run-out 0 km/h Pass/Fail [check]

[Radiation Dose]

Pass/Fail [check]

[Brake System]

Table with 4 columns: FL, FR, MR, RR weights and calculations for main brake, parking brake, R wheel brake, and diff b/w R&L axis.

[Engine]

Engine Result [check]
Fan belt Result [check]
Battery Result [check]
Master Cylinder Result [check]
Caburetor Result [check]
Fuel Pipes Result [check]
Injection Pump Result [check]
Wiring Haeness Result [check]
Generator Result [check]
Cooling System Result [check]
Manifolds Result [check]
Lubrication System R-134a Result [check]
CFC Result [check]

[Equipment]

Tool Result [check]
Jack Result [check]

[Accessory]

A/C [check] AT/MT: AT
Audio [check]
Navigation [check]
Alloy Wheel [check]

[Underbody]

Wheel Bearing Result [check]
Springs Result [check]
Shock Absorbers Result [check]
Suspension Fixing Result [check]
Torque Rod Result [check]
Gear Box Result [check]
Steering Rod/Arm Result [check]
Wheel Cylinder Result [check]
Brake Rod/Cable Result [check]
Breake Hose/Pipe Result [check]
Front axle Result [check]
Drive Shaft Result [check]
Propeller Shaft Result [check]
Axle Housing Result [check]
Differential Result [check]
Tyre Size Result [check]
Tyre Condition Result [check]
Tyre ETC Result [check]

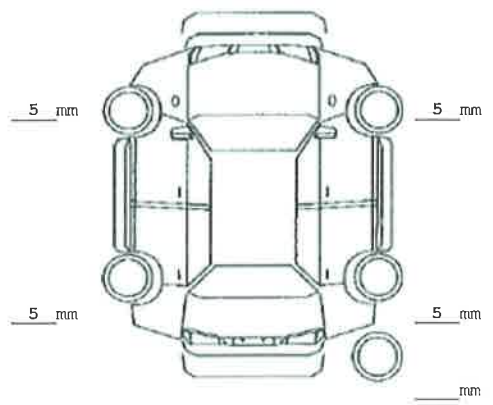

[Interior]

Steering Wheel Result [check]
Power Steering Result [check]
Horn Result [check]
Gauges Result [check]
Climate Control Result [check]
Door Result [check]
Windows Result [check]
Wipers Result [check]
Mirrors(Back & Sides) Result [check]
Shift Lever Result [check]
Safety Belts Result [check]
Brake Pedal Result [check]
Brake Booster Result [check]
Clutch Pedal Result [check]
Clutch Function Result [check]

[Lights]

Head lamp Result [check]
Indicator Result [check]
Rear Result [check]
Brake Result [check]
ETC Result [check]

[ETC]

Exhaust System Result [check]
Air Suspension Result [check]
Air Brake Result [check]
Fuel Tank Result [check]

[Damage]

Exterior Result [check]
Interior Result [check]
Underbody Result [check]

F=Repair A=Scratch U=Dent R=Rust CR=Crack D=Damage

[Result]

Pass [check]
Fail

Inspector Signature Kazuya Kawashima
Inspection Date 2020-03-13

[Reinspection]

Pass
Fail

Inspector Signature
Inspection Date2

[Fail Parts]

[Empty box for fail parts]

番号 01456  
整理番号 3971033002726274

# 輸出予定届出証明書 / Export Certificate

自動車登録番号 / Registration No. 登録年月日 / Registration Date 初年度登録年月 / First Reg. Date 車台番号 / Motor's serial number  
鹿児島 300 ふ 2627 令和 2 年 2 月 21 日 平成 21 年 2009 年 3 月 3 日 CW5W-5303187 4B12  
車名 / Trademark of the maker of the vehicle 型式 / Model 車台番号 / Motor's serial number  
[313]DBA-CW5W 車台番号 / Motor's serial number  
[35027]

所有者の氏名又は名称 株式会社 INDIAN  
所有者の住所 鹿児島県鹿児島市東開町3-60  
所有者の氏名又は名称 鹿児島県鹿児島市東開町3-60

使用者の住所 鹿児島県鹿児島市東開町3-60  
使用者の氏名又は名称 鹿児島県鹿児島市東開町3-60

使用の本拠の位置 鹿児島県  
自動車の種別 乗用車  
自動車の用途 乗用車  
自動車の型式指定番号 [003]

乗車定員 7人  
長さ 464cm  
幅 180cm  
高さ 168cm  
前軸重 860kg  
前々軸重 1530kg  
前後軸重 1915kg

輸出予定日 (証明書有効期間満了日) 令和 2 年 9 月 3 日  
輸出予定日 (証明書有効期間満了日) 令和 2 年 9 月 3 日

備考 [京都] 輸出予定届出 [京都] 輸出予定届出  
輸出に係る届出をした者は、輸出予定届出証明書の有効期間が満了した  
輸出されることなく、当該輸出が満了した日から15日以内に、最寄りの運輸  
支局等に当該輸出予定届出証明書を返納しなければなりません。  
以下余白

\*一時抹消中所有者 / Latest Owner \*  
IBC Japan 株式会社  
京都府京都市伏見区中島宮ノ前町64 [114256]  
[申請年月 / Date of Application]  
令和 2 (2020) 年 3 月 4 日  
[走行距離計表示値 / Mileage]  
[走行距離計表示値]



令和 2 年 3 月 4 日  
2020 year 3 month 4 day

Director-General of the District Transport Bureau or  
Director-General of the Transport Branch of the District Transport Bureau,  
Ministry of Land, Infrastructure, Transport and Tourism, Japan

京都運輸支局長  
WUOL

裏面もご覧下さい。

No. 01456

## EXPORT CERTIFICATE

License number	Last reg. Date	First reg. Month	Frame number
KAGOSHIMA 300 FU	2627 February, 21 , 2020	March, 2009	CW5W-5303187
Name		Model	
MITSUBISHI		DBA-CW5W	
Last owner's name		4B12	
IBC JAPAN KABUSHIKIGAISHA			
Above address			
KYOTO-FU KYOTO-SHI FUSHIMI-KU NAKAJIMA MIYANOMAE-CHO 64			
Last user's name			
*****			
Above address			
*****			
Above location			
*****			
Category	Purpose of use	Private or commercial	Style of Vehicle
MEDIUM	Passenger	PRIVATE	STATION WAGON
Displacement or outputpower	Fuel	Type No.	Code no.
2.35 L kw	PETROL	15182	1001
EXPIRY DATE	September, 3 , 2020		
REMARK: [ KAGOSHIMA ]			

March, 4 , 2020

KAGOSHIMA UNYU SHIKYOKU-CHO

We IBC JAPAN LTD. verify that this English translation of

Certificate Registration is exactly the same with the original Japanese edition